

SOLUTION
SERIES

TRK55B



**TECH
CRAFT**

GENERAL FEATURES

- | 55" wide Black Flat Panel stand with "mount" built in.
- | Creates that stunning "floating" look.
- | Brilliant silkscreen black glass against metal posts for a gorgeous complement to your Flat Panel set.
- | Broad wire management panel and ample component space provided.

TRK55B

Carton dimensions	Gross Weight	Volume	UPC code
(h) 6 1/4" / 157mm	132 lbs / 60 kg	4.7 cu ft / 0.13 cu m	6-23788-00485-7
(w) 59 1/4" / 1505mm	<i>Dimension and weight / volume information on this sheet is rounded. Specifications subject to change without notice.</i>		
(d) 22" / 560mm			

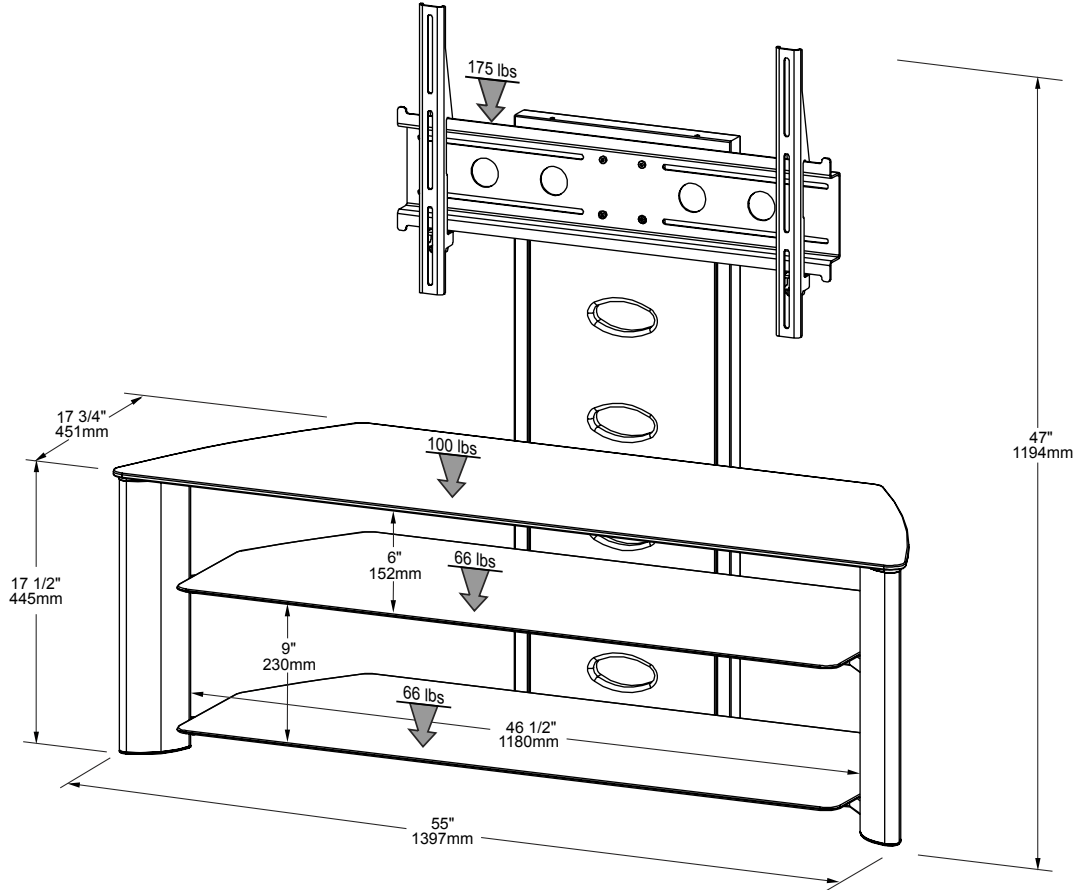

Techcraft Manufacturing Inc.

Copyright © Techcraft 2006. All rights reserved. No part of this drawing may be reproduced in any form by any photographic, electronic, mechanical or other means, or used in any information storage and retrieval system, without the written permission of Techcraft.

Hot Line : **1-888-476-8896**

Fax: (450) 622-3452

Email: sales@techcraft.net

Email: services@techcraft.net